



X-series Three Phase (Rectifier Module)

Overview:

The Eltek Valere X-series Three Phase rectifier is designed for applications requiring high capacity, high power density, and scalable growth. Utilizing a robust platform, this rectifier features industry-leading power density, flexibility, and ease of use. With a wide input voltage range and high efficiency, it provides the ideal solution for large power needs.

(Applications)

Scalable Power System

The X-series rectifier, in conjunction with the Eltek Valere Scalable Power System, is the ideal solution for such applications as central offices, mobile telephone switching offices (MTSO), and other switching centers that call for large power capacity—typically in the range of 1000 to 10,000 amps.

Flexibility and reliability

The X-series rectifier has a wide input AC voltage range, making inventory and installation extremely simple. Whether AC requirements are 380VAC or 480VAC, the X-series rectifier will fit your needs.

Plug and play

When used in the Scalable System the X-series rectifier is a hot-swappable unit. This allows the user to increase system output from 1000 amps to 10,000 amps without interrupting system performance.

Global compliance

The X-series rectifier can meet your needs anywhere in the world. We meet such global compliance standards as CSA certification, VDE certification, CE Marks, and NEBS compliance. Rest assured that the X-series rectifier will meet local industry standards.

(Features)

- Input operating voltage range 380VAC, and 480VAC in the same rectifier
- True three-phase input
- Up to 5800 watts of output power
- Only 2RU
- Efficiency up to 92.5%
- Operates in temperatures up to 65°C
- Power factor correction
- Hot-pluggable/hot-swappable
- 12 watts/in³
- AC OK, DC OK, and ALM (alarm) LED indicators
- Internal over temperature protection
- Internal OR-ing protection
- Internal surge protection (up to 6000V)
- CSA Certified (4Q07)
- VDE Certified (4Q07)
- CE Mark (4Q07)
- NEBS (4Q07)

(X-series Three Phase Rectifier Module)

Additional Technical Specifications

AC Input Specifications

X SERIES	X5000A3	X5000A4	NOTES
Input Voltage (nominal)	320 - 530Vac	208 - 530Vac	
Input Frequency (min)	47 Hz		
Input Frequency (max)	63 Hz		
Input Current (max)			
@ 208 Vac (amps)	n/a	18	
@ 240 Vac (amps)	n/a	15	
@ 320 Vac (amps)	11	11	
@ 380 Vac (amps)	10	10	
@ 400 Vac (amps)	9	9	
@ 480 Vac (amps)	8	8	
Inrush Current (max)	30 amps peak		Excludes X caps in the EMC input filter.
Power Factor (208Vac)	n/a	.99	Typical @ Full Load
Power Factor (480Vac)	.99	.93	Typical @ Full Load

DC Output Specifications

MAIN OUTPUT	X5000A3	X5000A4	NOTES
Vo Set Point (min/typ/max)	42/48/58V		X5000A4 automatically decreases current limit setpoint 4A per Volt above 54V
Regulation (min/max)	±1%		Total regulation line, load, aging & temperature)
Output Current (min/max amps)	0/100	0/100	
Current Limit Setpoint (max amps)	110	110	Current limit set point is adjustable via I2C or through Valere Network Interface Card.
Short Circuit Current (RMS amps)	35	35	
Output Noise*	<ul style="list-style-type: none"> o 40 mV rms typical (10kHz to 20MHz) o 32 dBrc (measured w/o external battery) o 250mV P-P (10 Khz to 20 Mhz) 		
Output Rise Time*	100/400 (msec)		Measured at 10 – 90% of final output level
Dynamic Response* (maximum)	3%		Change in output voltage within 10 msecs after a 10 to 100% load step change
Turn On Delay* (maximum)	3.5 sec		Measured from application of valid ac voltage to regulation set-point.
Adjustable Over-voltage Protection (min/max)	54/60 (Vdc) remotely config.		
Backup Over-voltage Protection	60 Vdc		
Load Sharing (min/max)	±5 (%) of full load		
Reverse Output Current (max)	0.5 amps		Internal reverse protection is provided.
Total Harmonic Distortion (THD)	<3% typical	<10% typical	At full rated current
Efficiency	92% typical		At 480Vac, 25-100% of rated current

AUXILIARY OUTPUT SPECIFICATIONS

AUXILIARY OUTPUT	X5000A3	X5000A4	NOTES
Output 1			
Nominal Voltage	12V		
Vmin/max	10.5 / 14		
Source Current Rating (min/max)	0 / 500mA		
Sink Current (max)	100mA		Current required for internal controls when AC is not present

NOTE: Output 1 operates independent of main DC output and is referenced to Vout-

PHYSICAL SPECIFICATIONS

PARAMETER	X5000A3	X5000A4	NOTES
Depth	323.85mm (12.75")		
Height	86.36mm (3.40")		
Width	263.90mm (10.39")		
Weight	8.18kg (18lbs)		

ENVIRONMENTAL SPECIFICATIONS

PARAMETER	Minimum	Maximum	UNIT	NOTES
Storage Temperature	-40	85	°C	
Operating Temperature	-40	65	°C	Power Derating: <ul style="list-style-type: none"> o 2% / °C above 50C for X5000A3 o 2% / °C above 40C for X5000A4
Humidity	5	95	%	Relative Humidity Non Condensing
Altitude	-200	8000	Ft	For operation above 8000' , maximum temperature is derated 2°C per 1000' for temps above 65

GENERAL REQUIREMENTS

Applicable Standards			
Seismic Rating	Zone 4, per GR-63-CORE	EN61000-4-2	Electrostatic discharge immunity test, 15kV air, 8kV contact
Radiated EMI	Conforms to EN55022, Level A	EN61000-4-3	Radiated radio-frequency, electromagnetic field immunity test. Level 3: 10 V/m
Conductive Emissions	EN55022, Level A	EN61000-4-4	Electrical fast transient/burst immunity test. 1kV
NEBS	EMC surge standards and electrical safety per GR-1089-CORE	EN61000-4-5	Surge immunity test. Installation class 4 6kV: Line to line 6kV: Line to ground
		EN61000-4-6	RF common mode. 3Vrms

Specifications are subject to change without notice

(X-series Three Phase Rectifier Module)

Dimension drawings

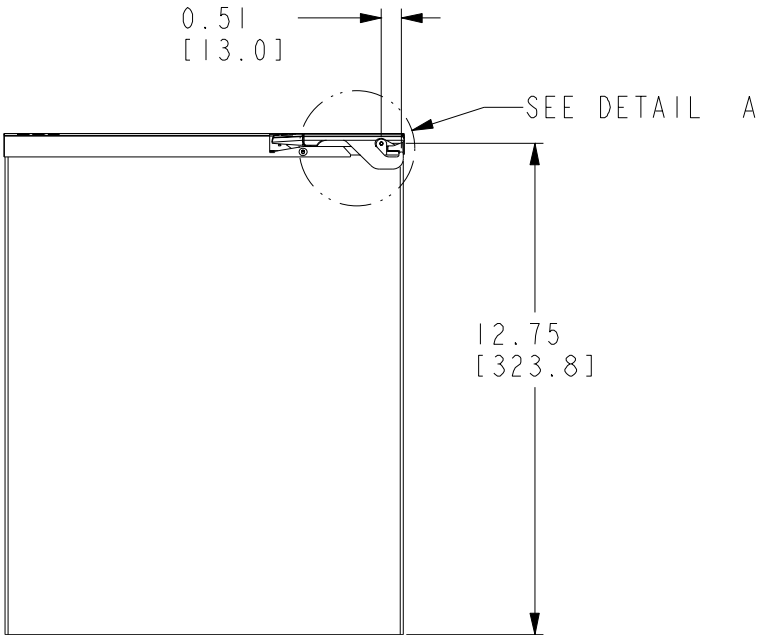
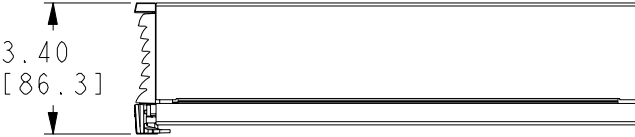
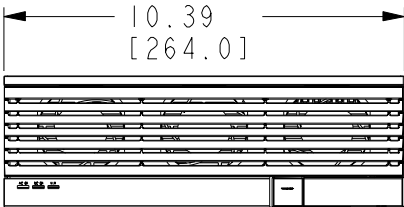
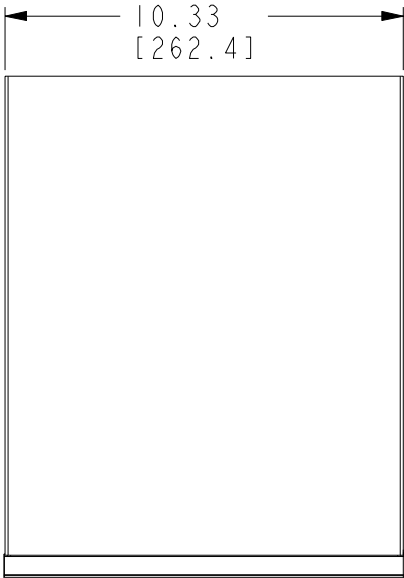

(X-series Three Phase Rectifier Module)

Dimension drawings

Latch View

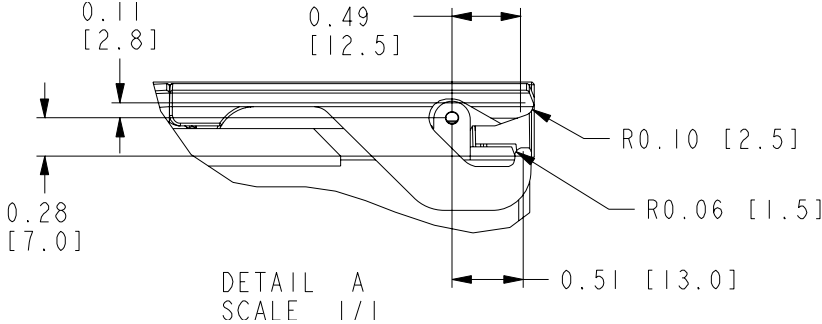

Rear View (AC and DC connectors)

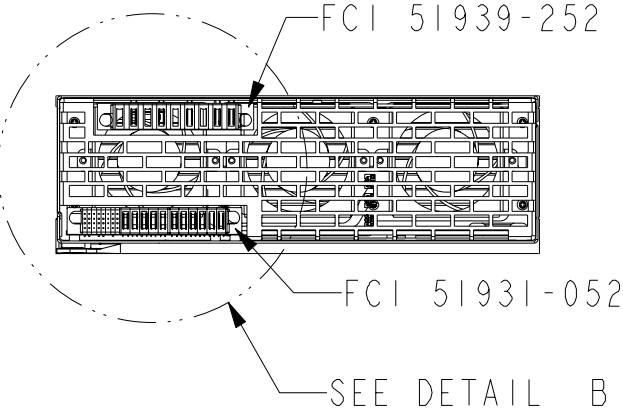

Rear View (Close up)

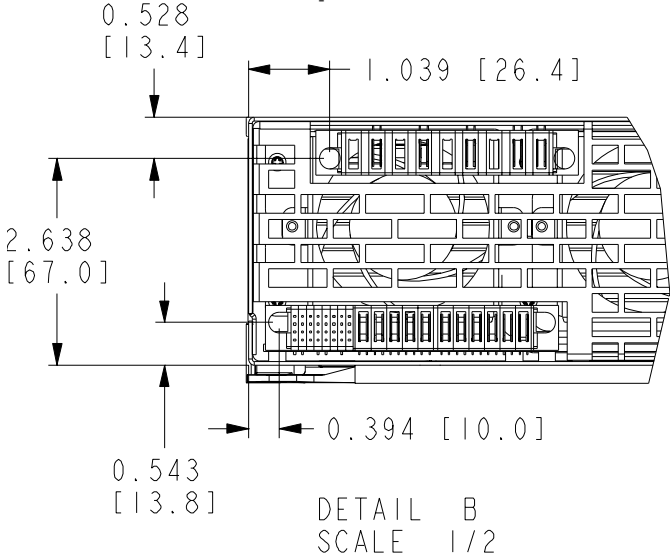

(X-series Three Phase Rectifier Module)

Rectifier Connector Pin-out Requirements

DC Output Connector

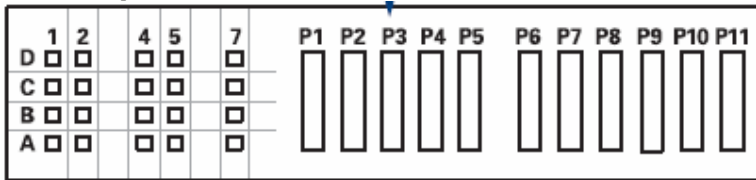

Unit DC output

Connector p/n:

51939-259LF

Mating Connector p/n:

51940-027LF (Straight) or 51915-122LF (Right Angle)

Supplier:

FCI/Berg

FCI NUMBERING	1	2	4	5	7
D	TEMP_ALARM	SDA	LOC3	Shelf-Bias	SHORT_PIN
C	MODULE_DISABLE	SCL	RESERVED	LOC2	REMOTE_SENSE-
B	AC_FAIL	MODULE_ALARM	ISHARE	LOC1	RESERVED
A	MODULE_PRESENT	LOGIC_GROUND	V_MARGIN	LOC0	REMOTE_SENSE+
P1	OUTPUT NEGATIVE				
P2					
P3					
P4					
P5					
P6	OUTPUT POSITIVE				
P7					
P8					
P9					
P10	RESERVED				
P11					

AC Input Connector

Connector P/N:

51939-252LF

Supplier:

FCI

FCI NUMBERING	PIN ASSIGNMENT
P1	CHASSIS GROUND
P2	CHASSIS GROUND
P3	NOT POPULATED
P4	PHASE 3
P5	NOT POPULATED
P6	PHASE 2
P7	NOT POPULATED
P8	PHASE 1
P9	NOT POPULATED

(Non Isolated Signals)

OUTPUT+ and OUTPUT-

Power blades used for connecting positive and negative power connections.

REMOTE_SENSE+ and REMOTE_SENSE-

These signals are used to compensate for distribution drop across the output distribution. The maximum voltage drop from the rectifier module to the remote sense connection (the complete round trip) must be maintained to less than 1V. The remote sense leads may be left un-terminated in applications where remote voltage regulation is not required.

ISHARE

All rectifiers ISHARE pins are tied together on the system backplane to support load sharing. This connection may be terminated between rectifiers or left un-terminated in systems where load share is not required.

SHORT_PIN

The short pin is used to disable the rectifier if not fully seated in a sys- tem. It is required to be tied to OUTPUT- in the system backplane in order for the rectifier to provide proper output voltage. It may not be left un-terminated.

V_MARGIN

V_Margin is used in systems where analog voltage margining up of the output voltage is required. The rectifier output voltage will default to the I²C setpoint value, which is factory set to 48.0V. Analog margining will then allow a host system to increase the rectifier above this I²C setpoint. It may be left un-terminated in systems where this feature is not required.

INPUT VOLTAGE	RECTIFIER OUTPUT VOLTAGE INCREASE
0V or Un-terminated	0V
5V	10V

(Isolated Signals)

Address Pins (LOC0, LOC1, LOC2, LOC3)

LOC0, LOC1, LOC2 and LOC3 are location pins used to set rectifier address in a system where the I²C bus is shared between rectifiers. They may be left un-terminated to generate logic 1 or connected to OUTPUT- to generate logic 0.

I²C Communications Bus (SCL, SDA)

The I²C Communications Bus provides information about internal rectifier conditions as well as full control of output voltage and alarming set points. SCL and SDA are common data signals and can be wired directly to a sys- tem controller or on a common shared bus between the rectifiers in a system and the main system controller. The rectifiers communicate via the proprietary Valere Communication Protocol. Contact your Valere Power representative for technical assistance in interfacing to the rectifiers using this interface protocol. The I²C Bus signals are logic referenced to LOGIC_GROUND. The internal bias for the I²C isolation circuit will support a 10V common mode voltage differential to OUTPUT-.

(Non Isolated Signals cont.)

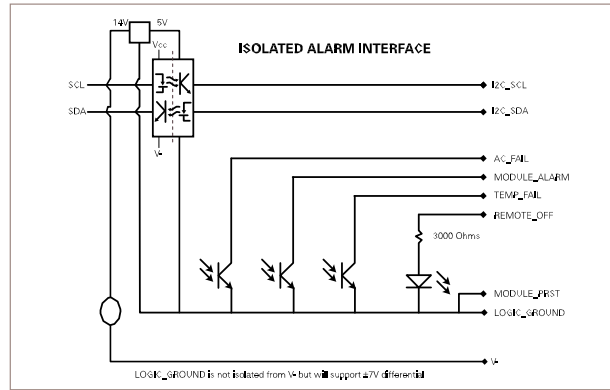

MODULE_PRESENT

This signal is a connection to logic ground. It may be used to determine the presence of a rectifier module in a system location.

AC_FAIL_ALARM

This signal is an opto-isolated open collector signal referenced to LOGIC_GND within each rectifier. AC_ALARM is a normally closed signal which signifies the presence of an alarm with a high impedance. AC_ALARM indicates the presence of valid AC input voltage to the rectifier.

MODULE_ALARM

This signal is an opto-isolated open collector signal referenced to LOGIC_GND within each rectifier. MODULE_ALARM is a normally closed signal which signifies the presence of an alarm with a high impedance. MODULE_ALARM is designed to provide an power fail warning to indicate the pending loss of DC voltage during line drop conditions. MODULE_ALARM is asserted at least 5mSec prior to loss of DC output voltage during these conditions.

OVERTEMP_ALARM

This signal is an opto-isolated open collector signal referenced to LOGIC_GND within each rectifier. OVERTEMP_ALARM is a normally closed signal which signifies the presence of an alarm with high impedance. OVERTEMP_ALARM indicates that the rectifier module has shut down due to an over-temperature condition.

MODULE_DISABLE

This signal is a current limited input designed to accept a 3.3V to 5V input voltage. Applying a voltage between these pins will result in disabling the DC output voltage from the rectifier. This signal may be left un-terminated in systems where MODULE_DISABLE is not required or is implemented via the I²C Interface.