

TELECOM RANGE

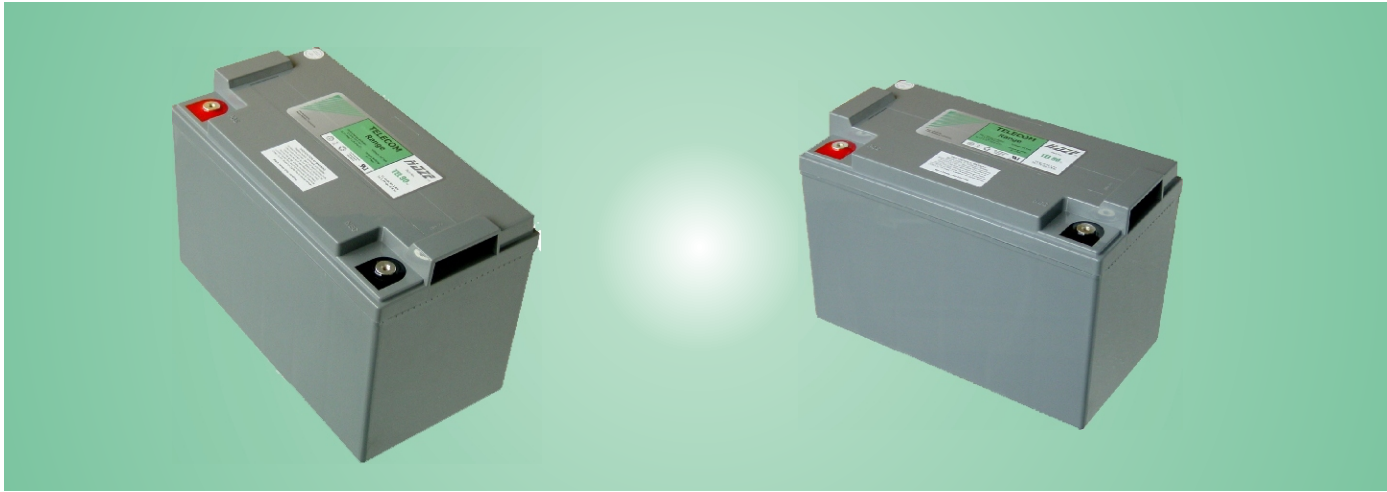
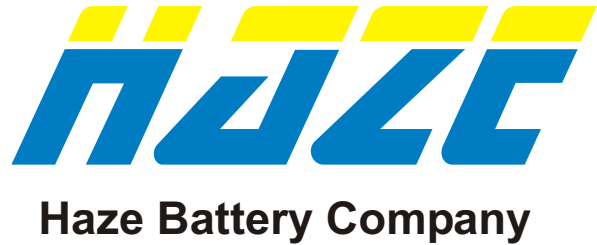

Model No. TEL 90 (12 Volts, 91.1 Ah at 8 hour Rate to 1.75 vpc)
Valve Regulated Lead Acid Battery for communications
standby power applications

Innovative Features

- Completely maintenance free, sealed construction eliminates the need for watering
- Fully tank formed plates
- Analytical Grade electrolyte
- Spill proof / leak proof
- Valve regulated Max internal pressure 2.5 psi
- Multi-position usage
- ABS Case & Cover Flame retardent meets UL 94 VO requirements
- Low self discharge
- FAA and IATA approved as non-hazardous
- Built to comply with IEC 896-2, DIN 43534, BS 6290 Pt4, Eurobat, Telcordia SR 4228
- UL Approval, ISO9001

Ampere Hour Capacity at 77°F (25°C) to 1.75 vpc

Discharge Time in Hrs	1	2	3	4	5	6	7	8	10
Ampere Hour Capacity	69	76.4	78.7	80.8	83.3	87.2	89.5	91.1	93.6

AGM Range
Sealed Lead Acid 12 Volt Bloc

Specifications

Nominal Voltage		12V	
Nominal Capacity		109.8 Ah	
Dimensions	Total Height (Inc terminals)	8.39 inches	213 mm
	Length	13.07 inches	332 mm
	Width	6.85 inches	174 mm
	Weight	71.16 lbs	32.2 Kg



Haze Battery Company Ltd

Characteristics

Capacity 77°F (25°C) to 1.7 vpc	20 hour rate	109.8 Ah
	10 hour rate	96.4 Ah
	5 hour rate	85.7 Ah
	1 hour rate	69.8 Ah
	15 min rate	51.5 Ah
	Internal Resistance	4 mOhms
Capacity correction for temperature Variations (C20)	104°F (40°C)	102%
	68°F (20°C)	100%
	32°F (0°C)	85%
	5°F (-15°C)	65%
Self Discharge 77°F (25°C)	Capacity after 1 month storage	98%
	Capacity after 3 months storage	94%
	Capacity after 6 months storage	86%
Short Circuit Current 77°F (25°C)	3000	
Terminal	Standard	14mm Insert M6 thread
Charging (Constant Voltage)	Float	2.27 - 2.30 vpc (59 - 77°F)

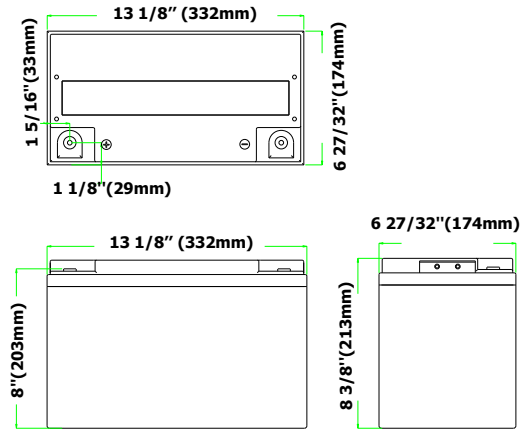

End V per Cell	Ampere Hour at 77°F (25°C)									
	1 hr	2 hr	3 hr	4 hr	5 hr	8 hr	10 hr	12 hr	20 hr	
1.85	64.6	74.1	76.8	78.4	80.1	88.0	90.0	92.4	102.0	
1.80	68.2	75.7	78.3	80.2	82.8	90.3	93.1	95.5	106.2	
1.75	69.0	76.4	78.7	80.8	83.3	91.1	93.6	96.1	107.0	
1.70	69.8	78.0	81.1	83.4	85.7	93.7	96.4	99.0	109.8	

End V per Cell	Constant Amps Discharge - Amps at 77°F (25°C)											
	1 hr	2 hr	3 hr	4 hr	5 hr	8 hr	10 hr	12 hr	20 hr	24 hr	72 hr	100 hr
1.85	64.60	37.05	25.60	19.60	16.02	11.00	9.00	7.70	5.10	4.28	1.41	1.01
1.80	68.20	37.85	26.10	20.05	16.56	11.29	9.31	7.96	5.31	4.41	1.48	1.06
1.75	69.00	38.20	26.23	20.20	16.66	11.39	9.36	8.01	5.35	4.44	1.51	1.08

Specifications

Design Life	12 Years
Operating Temperature	-4 °F to 122 °F
Grid alloy	Calcium / Tin lead alloy
Plates	Flat Pasted
Separator	Absorbant Glass Mat
Active material	Very high purity lead
Charge Voltage	Float 2.25 - 2.30 VPC @77 °F Cycling 2.35 @77 °F Max. 2.4 VPC Max ripple 0.05C (A)
Electrolyte	Sulphuric acid Analytical grade purity
Venting Valve	EPDM Rubber 1.5 to 2 psi (10.5 - 14 KPa) release pressure. Resealing at 1 psi (7 KPa)
Torque setting	The recommended torque value for all types is 44-62 inch-pounds

Terminal Details

Insert are made from brass with copper, nickel and silver plating giving excellent mechanical, electrical and corrosion resistant properties.

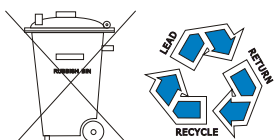

Haze Battery Company keenly encourages environmental awareness; PLEASE follow guidelines for the recycling /disposal of lead.

Pb CORE Telecom Systems



888-375-8826



www.coretelecom.net
Ver. 20050915