



## E2 Optics 1.25Gbps SFP Transceiver

### Description

The GLC-LH-SM single mode transceiver is a small form factor pluggable module for bi-directional serial optical data communications such as Gigabit Ethernet 1000BASE-LX and Fiber Channel 1x SM-LC-L FC-PI. This transceiver has an SFP 20-pin connector to allow hot plug capability. This module is designed for single mode fiber and operates at a nominal wavelength of 1310 nm.



The transmitter section uses a multiple quantum well laser and is Class 1 Laser compliant according to International Safety Standard IEC-60825. The receiver section uses an integrated InGaAs detector preamplifier (IDP) mounted in an optical header and a limiting post-amplifier IC.

The GLC-LH-SM is designed to be compliant with SFF-8472 SFP Multi-source Agreement (MSA).

*ALL OF OUR TRANSCEIVERS ARE TIER 1 LASERS, MANUFACTURED TO OEM SPECIFICATIONS, ROHS (LEAD FREE), TAA COMPLIANT AND COMPLIANT WITH THE SFP MSA (MULTISOURCE AGREEMENT) AND COME WITH A LIFETIME WARRANTY.*

### Features

- Operating data rate up to 1.25Gbps.
- 1310 nm FP LD Transmitter.
- Distance up to 10km.
- Single 3.3V Power supply and TTL Logic Interface.
- Duplex LC Connector Interface.
- Hot Pluggable.
- Operating Case Temperature Standard: 0 ~+70°C.
- Compliant with MSA SFP Specification.
- Digital diagnostic monitor interface Compatible with SFF-8472

### Applications

- Gigabit Ethernet Switches and Routers.
- Fiber Channel Switch Infrastructure.
- XDSL Applications.
- Metro Edge Switching.

## Regulatory Compliance

Feature	Standard	Performance
Electrostatic Discharge (ESD) to the Electrical Pins	MIL-STD-883E Method 3015.7	Class 1(>500 V) Isolation with the case
Electromagnetic Interference (EMI)	FCC Part 15 Class B	Compatible with standards
Laser Eye Safety	FDA 21CFR 1040.10 and 1040.11 EN60950, EN (IEC) 60825-1,2	Compatible with Class I laser product. Compatible with T üV standards
Component Recognition	UL and CUL	UL file E317337
Green Products	RoHS	RoHS6

## Absolute Maximum Ratings

Parameter	Symbol	Min.	Max.	Unit
Storage Temperature	Ts	-40	+85	°C
Supply Voltage	Vcc	-0.5	3.6	V

## Recommended Operating Conditions

Parameter	Symbol	Min.	Typical	Max.	Unit
Operating Case Temperature	Ta	GLC-LH-SM	0	70	°C
Power Supply Voltage	Vcc	3.15	3.3	3.45	V
Power Supply Current	Icc			300	mA
Surge Current	ISurge			+30	mA
Baud Rate			1.25		GBaud

## Performance Specifications - Electrical

Parameter	Symbol	Min.	Typical	Max.	Unit	Notes
<b>TRANSMITTER</b>						
VLPECL Inputs(Differential)	Vin	400		2500	mVp	AC coupled inputs
Input Impedance (Differential)	Zin	85	100	115	ohms	Rin > 100 kohms @ DC
Tx_DISABLE Input Voltage - High		2		3.45	V	
Tx_DISABLE Input Voltage - Low		0		0.8	V	
Tx_FAULT Output Voltage - High		2		Vcc+0.3	V	Io=400µA; HOst Vcc
Tx_FAULT Output Voltage - Low		0		0.5	V	Io= -4.0mA

## Performance Specifications - Electrical

Parameter	Symbol	Min.	Typical	Max.	Unit	Notes
<b>RECEIVER</b>						
LVPECL Outputs (Differential)	Vout	400	800	1200	mVpp	AC coupled outputs
Output Impedance (Differential)	Zout	85	100	115	ohms	
Rx_LOS Output Voltage - High		2		Vcc+0.3	V	Io=400µA; HOst Vcc
Rx_LOS Output Voltage - Low		0		0.8	V	Io= -4.0mA
MOD_DEF (0:2)	VoH	2.5			V	With Serial ID
	VoL	0		0.5	V	

## Optical and Electrical Characteristics

Parameter	Symbol	Min.	Typical	Max.	Unit
9µm Core Dia. SMF	GLC-LH-SM			10	Km
Data Rate			1.25		Gbps
<b>TRANSMITTER</b>					
Centre Wavelength	$\lambda_c$	1260	1310	1360	nm
Spectral Width (RMS)	$\sigma$			3	nm
Average Output Power GLC-LH-SM	Pout	-10		-3	dBm
Extinction Ratio	EX	9			dB
Rise/Fall Time(20% ~80%)	tr/tf			1.2	ns
Total Jitter	TJ			56.5	ps
Output Optical Eye	ITU-T G.957 Compliant				
Data Input Swing Differential	Vin	500		2000	mV
Input differential Impedance	Zin	90	100	110	$\Omega$
TX Disable	Disable	2.0		Vcc+0.3	V
	Enable	0		0.8	
TX_Fault	Fault	2.0		Vcc+0.3	V
	Normal	0		0.8	
TX_Disable Assert Time	t_off			10	us
<b>RECEIVER</b>					
Centre Wavelength	$\lambda_c$	1100		1600	nm
Receiver GLC-LH-SM	PIN	-		-20	dBm
Output Differential Impedance	Pin	90	100	110	$\Omega$
Data Input Swing Differential	Vout	370		2000	mV
Rise/Fall Time	Tr/tf			2.2	ns
LOS De-Assert	LOS <sub>D</sub>			-24	dBm
LOS De-Assert	LOS <sub>A</sub>	-40			dBm
LOS	High		2.0	Vcc+0.3	V
	Low		0	0.8	

## SFP Transceiver Electrical Pad Layout

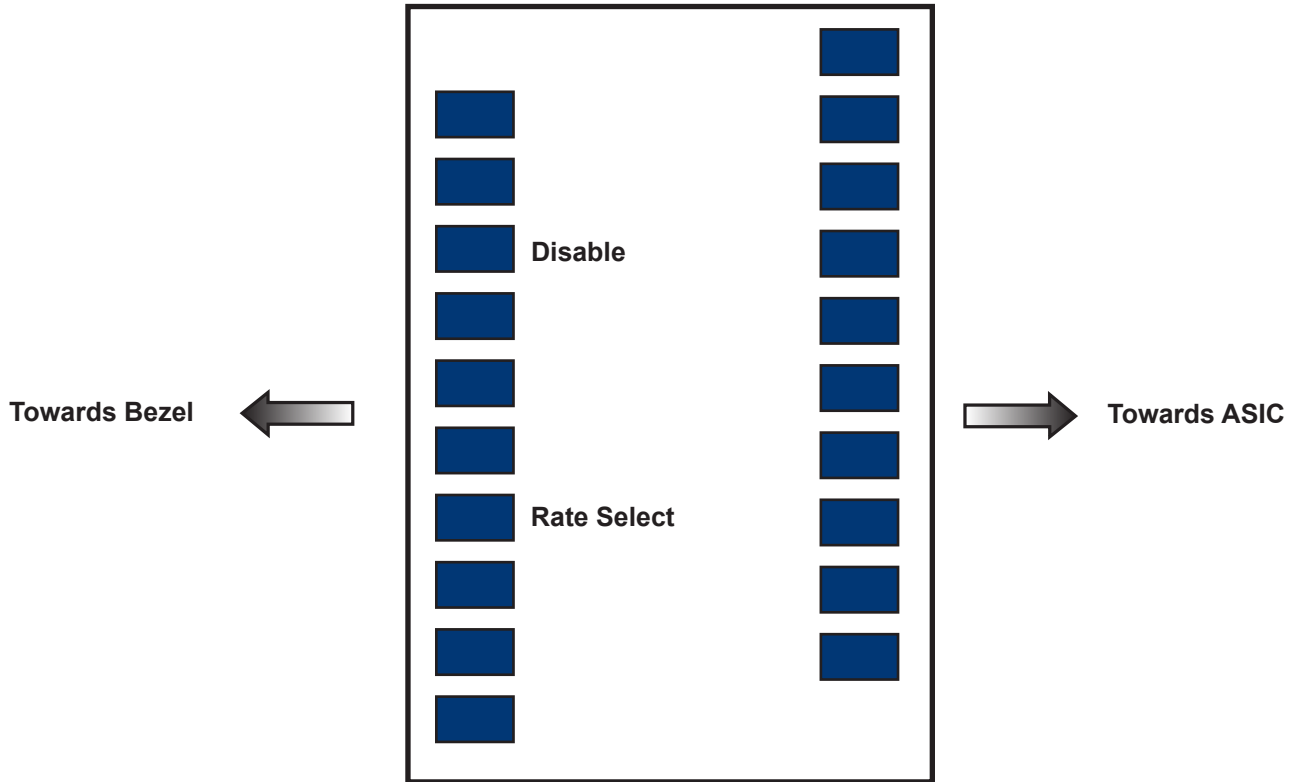

## Pin Function Definitions

Pin Number	Name	Function	Plug Seq.	Notes
1	Vee T	Transmitter Ground	1	
2	TX Fault	Trasmitter Fault Indication	3	Note 1
3	TX Disable	Transmitter Disable	3	Note 2, Module disables on high or open
4	MOD-DEF2	Module Definition 2	3	Note 3, Data line for Serial ID.
5	MOD-DEF1	Module Definition 1	3	Note 3, Clock line for Serial ID.
6	MOD-DEF0	Module Definition 0	3	Note 3, Grounded within the module.
7	Rate Select	Not Connect	3	Function not available
8	LOS	Loss of Signal	3	Note 4
9	VeeR	Receiver Ground	1	Note 5
10	VeeR	Receiver Ground	1	Note 5
11	VeeR	Receiver Ground	1	Note 5
12	RD-	Inv. Received Data Out	3	Note 6
13	RD+	Received Data Out	3	Note 7
14	VeeR	Receiver Ground	1	Note 5
15	VccR	Receiver Power	2	3.3 ± 5%, Note 7
16	VccT	Transmitter Power	2	3.3 ± 5%, Note 7
17	VeeT	Transmitter Ground	1	Note 5
18	TD+	Transmit Data In	3	Note 8
19	TD-	Inv. Transmit Data In	3	Note 8
20	VeeT	Transmitter Ground	1	Note 5

## Notes:

- 1) TX Fault is an open collector/drain output, which should be pulled up with a 4.7K – 10K  $\Omega$  resistor on the host board. Pull up voltage between 2.0V and VccT, R+0.3V. When high, output indicates a laser fault of some kind. Low indicates normal operation. In the low state, the output will be pulled to < 0.8V.
- 2) TX disable is an input that is used to shut down the transmitter optical output. It is pulled up within the module with a 4.7 – 10 K  $\Omega$  resistor. Its states are:
  - Low (0 – 0.8V): Transmitter on
  - (>0.8, < 2.0V): Undefined
  - High (2.0 – 3.465V): Transmitter Disabled
  - Open: Transmitter Disabled
- 3) Mod-Def 0,1,2. These are the module definition pins. They should be pulled up with a 4.7K – 10K resistor on the host board. The pull-up voltage shall be VccT or VccR (see Section IV for further details). Mod-Def 0 is grounded by the module to indicate that the module is present Mod-Def 1 is the clock line of two wire serial interface for serial ID Mod-Def 2 is the data line of two wire serial interface for serial ID
- 4) LOS (Loss of Signal) is an open collector/drain output, which should be pulled up with a 4.7K – 10K  $\Omega$  resistor. Pull up voltage between 2.0V and VccT, R+0.3V. When high, this output indicates the received optical power is below the worst-case receiver sensitivity (as defined by the standard in use). Low indicates normal operation. In the low state, the output will be pulled to < 0.8V.
- 5) VeeR and VeeT may be internally connected within the SFP module.
- 6) RD-/+ : These are the differential receiver outputs. They are AC coupled 100  $\Omega$  differential lines which should be terminated with 100  $\Omega$  (differential) at the user SERDES. The AC coupling is done inside the module and is thus not required on the host board. The voltage swing on these lines will be between 370 and 2000 mV differential (185 –1000 mV single ended) when properly terminated.
- 7) VccR and VccT are the receiver and transmitter power supplies. They are defined as 3.3V  $\pm$ 5% at the SFP connector pin. Maximum supply current is 300mA. Recommended host board power supply filtering is shown below. Inductors with DC resistance of less than 1 ohm should be used in order to maintain the required voltage at the SFP input pin with 3.3V supply voltage. When the recommended supply-filtering network is used, hot plugging of the SFP transceiver module will result in an inrush current of no more than 30mA greater than the steady state value. VccR and VccT may be internally connected within the SFP transceiver module.
- 8) TD-/+ : These are the differential transmitter inputs. They are AC-coupled, differential lines with 100  $\Omega$  differential termination inside the module. The AC coupling is done inside the module and is thus not required on the host board. The inputs will accept differential swings of 500 – 2400 mV (250 – 1200mV single-ended), though it is recommended that values between 500 and 1200 mV differential (250 – 600mV single-ended) be used for best EMI performance.

## EEPROM

The serial interface uses the 2-wire serial CMOS EEPROM protocol defined for the ATMEL AT24C02/04 family of components. When the serial protocol is activated, the host generates the serial clock signal (SCL). The positive edge clocks data into those segments of the EEPROM that are not write protected within the SFP transceiver. The negative edge clocks data from the SFP transceiver. The serial data signal (SDA) is bi-directional for serial data transfer. The host uses SDA in conjunction with SCL to mark the start and end of serial protocol activation. The memories are organized as a series of 8-bit data words that can be addressed individually or sequentially. The Module provides diagnostic information about the present operating conditions. The transceiver generates this diagnostic data by digitization of internal analog signals. Calibration and alarm/warning threshold data is written during device manufacture. Received power monitoring, transmitted power monitoring, bias current monitoring, supply voltage monitoring and temperature monitoring all are implemented. The diagnostic data are raw A/D values and must be converted to real world units using calibration constants stored in EEPROM locations 56 – 95 at wire serial bus address A2h. The digital diagnostic memory map specific data field define as following .For detail EEPROM information, please refer to the related document of SFF 8472 Rev 9.3

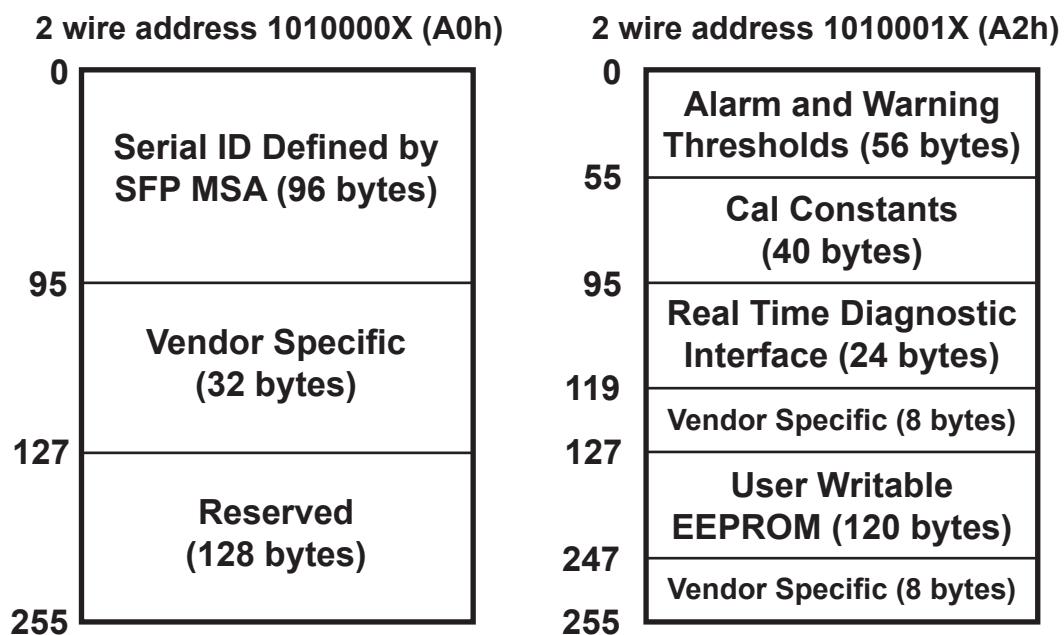

## Ordering Information

Pin Number	Data Rate	Laser	Fibre Type	Distance	Optical Interface	DDMI
GLC-LH-SM	1.25Gbps	1310nm FP	SMF	10km	LC	Optional

## Recommend Circuit Schematic

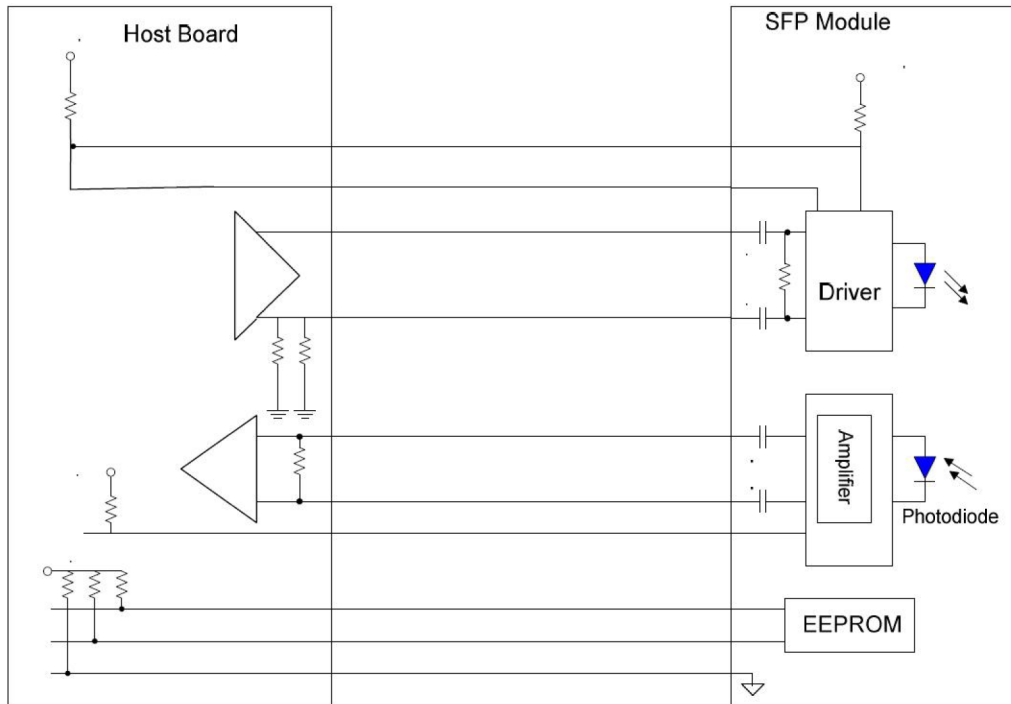

## Mechanical Specifications

